

Series AC Spacers/Brackets Accessories

Spacer

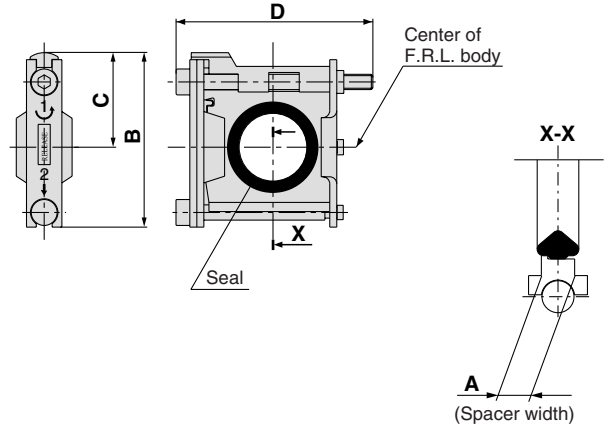
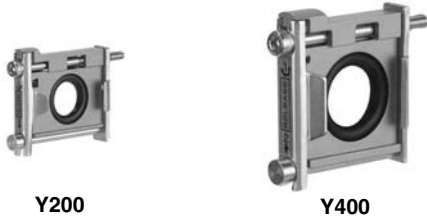

Model	A	B	C	D	Applicable model
Y100	6	27	15	33	AC10, AC10A, AC10B
Y200	3	35.5	18.5	48	AC20□
Y300	4	47	26	59	AC25□, AC30□
Y400	5	57	31	65	AC40□
Y500	5	61	33	75	AC40□-06
Y600	6	75.5	41	86	AC50, AC55, AC60 AC50A, AC60A AC50B, AC55B, AC60B

Replacement Parts

Description	Material	Part no.					
		Y100	Y200	Y300	Y400	Y500	Y600
Seal	HNBR ^{Note 2)}	Y100P-060AS ^{Note 1)}	Y200P-061S	Y300P-060S	Y400P-060S	Y500P-060S	Y600P-060S

Note 1) Assembly of 2 O-rings

Note 2) NBR is used for Y100 spacer because of no direct contact with fluid.

Spacer with Bracket

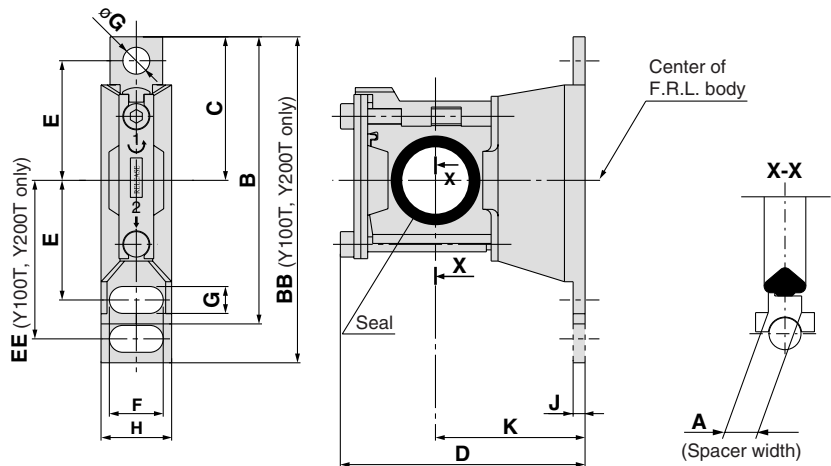
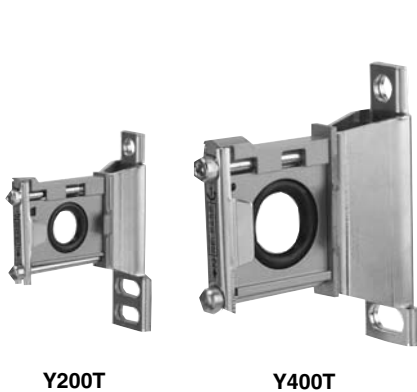

Model	A	B	BB	C	D	E	EE	F	G	øG	H	J	K	Applicable model
Y100T	6	—	56	24.5	40.5	20	27	6.8	4.5	4.5	14	2.8	25	AC10□
Y200T	3	—	67	29	53	24	33	12	5.5	5.5	19	3.2	30	AC20□
Y300T	4	82	—	41	68	35	—	14	7	7	21	4	41	AC25□, AC30□
Y400T	5	96	—	48	81.5	40	—	18	9	9	26	4	50	AC40□
Y500T	5	96	—	48	86	40	—	18	9	9	27	4.6	50	AC40□-06
Y600T	6	120	—	60	112	50	—	20	11	11	31	6.4	70	AC50, AC55, AC60, AC50A, AC60A, AC50B, AC55B, AC60B

Replacement Parts

Description	Material	Part no.					
		Y100T	Y200T	Y300T	Y400T	Y500T	Y600T
Seal	HNBR ^{Note 2)}	Y100P-060AS ^{Note 1)}	Y200P-061S	Y300P-060S	Y400P-060S	Y500P-060S	Y600P-060S

Note 1) Assembly of 2 O-rings

Note 2) NBR is used for Y100T spacer because of no direct contact with fluid.

Série AC

Accessories (Entretoise/Fixations)

Entretoise

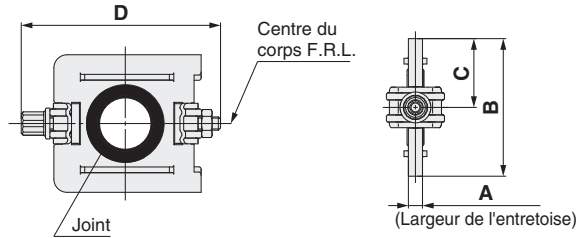

Modèle	A	B	C	D	Modèle compatible
Y100-A	6	17.9	9	35.4	AC10□-A
Y200-A	3.2	31.2	15.6	44.9	AC20□-B
Y300-A	4.2	43.4	21.7	57.9	AC25□-B, AC30□-B
Y400-A	5.2	53	26.5	68.5	AC40□-B
Y500-A	5.2	57	28.5	75.6	AC40□-06-B
Y600-A	6.2	67.6	33.8	92.5	AC50□-B, AC55□-B, AC60□-B

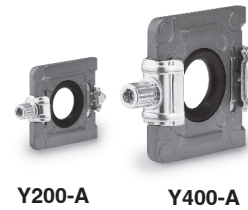

Pièces de rechange

Description	Matière	Réf.					
		Y100-A	Y200-A	Y300-A	Y400-A	Y500-A	Y600-A
Joint	HNBR (NBR) ^{Note 1)}	Y120P-050AS ^{Note 2)}	Y220P-050S	Y320P-050S	Y420P-050S	Y520P-050S	Y620P-050S

Note 1) (): Taille 10

Note 2) Assemblée de 2 joints toriques.

Entretoise de fixation

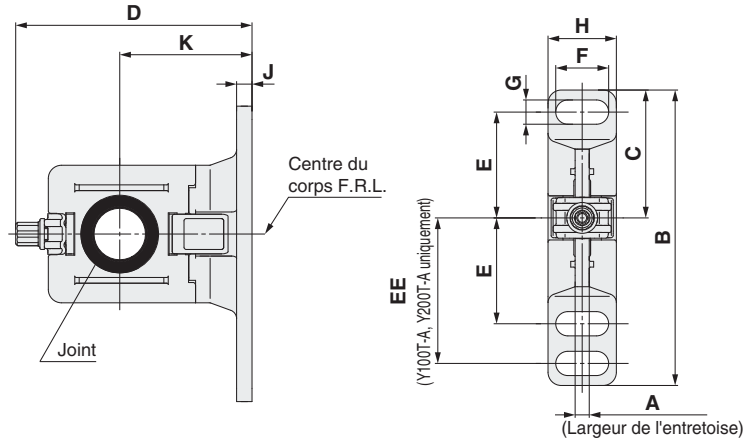

Modèle	A	B	C	D	E	EE	F	G	H	J	K	Modèle compatible
Y100T-A	6	56	24.5	43.6	20	27	6.8	4.5	13	3	25	AC10□-A
Y200T-A	3.2	67	29	53.4	24	33	12	5.5	15.5	3.5	30	AC20□-B
Y300T-A	4.2	82	41	71.5	35	—	14	7	19	4	41	AC25□-B, AC30□-B
Y400T-A	5.2	96	48	86.1	40	—	18	9	26	5	50	AC40□-B
Y500T-A	5.2	96	48	89.6	40	—	18	9	26	5	50	AC40□-06-B
Y600T-A	6.2	120	60	118	50	—	20	11	31.2	6	70	AC50□-B, AC55□-B, AC60□-B

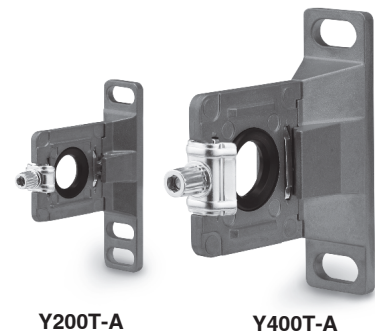

Pièces de rechange

Description	Matière	Réf.					
		Y100T-A	Y200T-A	Y300T-A	Y400T-A	Y500T-A	Y600T-A
Joint	HNBR (NBR) ^{Note 1)}	Y120P-050AS ^{Note 2)}	Y220P-050S	Y320P-050S	Y420P-050S	Y520P-050S	Y620P-050S

Note 1) (): Taille 10

Note 2) Assemblée de 2 joints toriques.